

## Silicon Photomultiplier Modules

SensL silicon photomultiplier (SPM) detectors are a range of high gain, single-photon sensitive, visible light sensors. They have performance characteristics similar to a conventional PMT, whilst benefiting from the practical advantages of solid-state technology: low operating voltage, robustness, compactness, insensitivity to magnetic fields and light over-exposure.

The MiniSL is a high-performance detector module offering a plug-and-play solution to many demanding applications. It consists of one of SensL's leading SPM detectors (1mm or 3mm) mounted in a TO8 can and cooled using a Peltier thermoelectric cooler. This reduced temperature allows improved performance over room temperature operation, due to the reduction in dark count noise. The MiniSL also includes preamplification, temperature control and power supply electronics that together create a module that combines high-performance with ease of use.

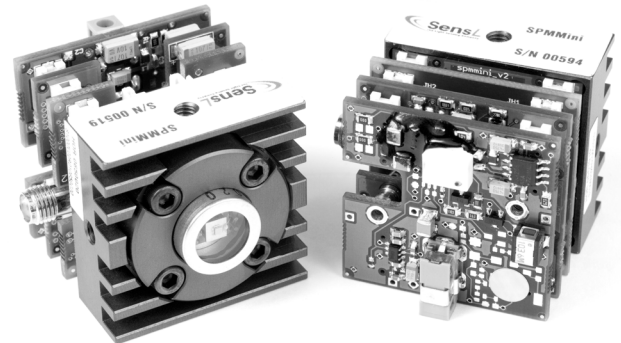

### PERFORMANCE PARAMETERS (All values are typical)

	10000 series	30000 series
	10035 <sup>2</sup>	30035 <sup>2</sup>
Spectral Range	400 – 1000nm	
Peak wavelength ( $\lambda_p$ )	500nm	
PDE at $\lambda_p$ <sup>1,5</sup>	14%	
Gain <sup>5</sup>	2.4x10 <sup>6</sup>	
Dark Count Rate ( <i>Typical</i> )	44 kHz	365 kHz <sup>6</sup>
Single photoelectron pulse height	11mV	4mV
Microcell Recovery Time <sup>5</sup>	130ns	130ns
Cross-talk (charge duplication probability) <sup>3,5</sup>	21%	
Excess Noise Factor <sup>4,5</sup>	1.2	

<sup>1</sup> Includes the effects of crosstalk and afterpulsing

<sup>2</sup> SensL naming convention: 10000 represents a 1mm detector, 035 a 35 $\mu$ m microcell. Therefore, the 10035 is a 1mm detector with 35 $\mu$ m microcells.

<sup>3</sup> Vinogradov et al., IEEE Trans. Nucl. Sci., Vol: 58, (2011)

<sup>4</sup> Hakim et al., IEEE Trans. Electron Devices, Vol. 37, No.3 (1990)

<sup>5</sup> Measured at 20°C

<sup>6</sup> Dark count is based on the dark current measurement and is not directly measurable from the SMA output due to the Gain Bandwidth and signal amplitude.

### GENERAL PARAMETERS

	10000 series	30000 series
	10035	30035
Active area (Approx.)	1 x 1 mm <sup>2</sup>	3 x 3 mm <sup>2</sup>
No. of microcells	576	4774
Microcell size	35 $\mu$ m	
Recommended operating temperature range	0°C - +30°C	
Recommended storage temperature range	-20°C - +60°C	
Breakdown voltage ( $V_{Br}$ )	26.5V	
Detector operating set point <sup>7</sup>	$V_{Br} + 2V$	
Module dimensions (H x W x L)	45 x 35 x 40 mm <sup>3</sup>	
Power requirements	+5V	
Cooled temperature	-10°C	
Module weight	70g	
Settling time	10 sec	
Signal polarity	Negative	

<sup>7</sup> Set at factory.

## MODULE ELECTRONICS

The MiniSL module comes complete with a number of electronics boards that together provides a simple 'plug and play' detection solution, eliminating the need for separate bench-top supplies and other electronics.

### Transimpedance Preamplifier

The transimpedance preamplifier converts the raw current from the detector into a voltage and has a gain setting that provides a 2V output swing across the dynamic range of the detector. This preamplifier is ideal for applications that require detection of continuous signals where the detector output is integrated over time.

Preamplifier		
Gain (by detector size)	1mm	3mm
	2200 V/A	470 V/A
Low frequency cut-off	DC	
Output voltage maximum	2V	
Output impedance	50Ω	
Bandwidth (3db)	20MHz	
Output connector	SMA	
Power Supply		
Input jack	Lumburg, 0.65mm LV socket	

### Power Supply

The on-board power supply simplifies the input power requirements of the MiniSL. Instead of the requirement for the user to supply a number of separate voltages for the preamp and detector bias, the module generates all required voltages from a single +5V input. An input jack socket enables power to be supplied from a 5VDC mains adapter (included) or bench supply. The bias voltage for the detector is optimally set during production, however details of how to adjust the bias voltage via a potentiometer are available upon request.

### Cooling Control

The MiniSL has cooling electronics ensure the attainment of the stated dark count values up to an ambient temperature of +30°C. Cooling is achieved with a single-stage TEC Peltier cooler controlled by the module. A pulse width modulator is used to maintain a temperature to within 0.1°C based upon feedback from a thermistor situated beside the detector in the hermetically sealed TO8 can. The module features current soft-start for controlled start-up to prevent high current in-rush and an output slew rate limiter to reduce system noise.

## PERFORMANCE GRAPHS\*

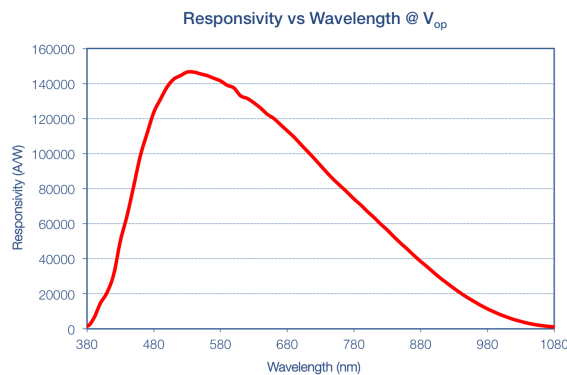
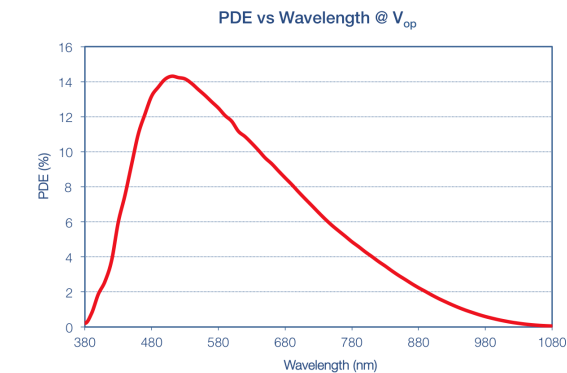

\* Measured at room temperature

## OPTIONS

### C-Mount Adapter

A C-Mount Adapter option is available that attaches to the collar around the TO8 can and facilitates the attachment of various standard C-Mount fittings, including filters and lenses. This is an ideal solution for attaching light collection lenses.

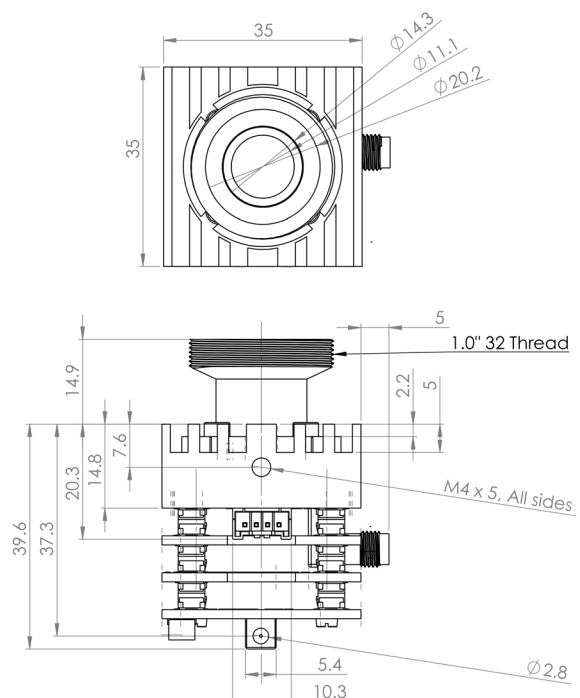

**Fiber Coupler**

SensL offers the following pigtail lens style photodiode-to-multimode (MM) fiber coupler to couple light signals from a source via MM glass fiber to MiniSL modules. A receptacle is mounted onto the collar of the MiniSL module which holds the 400µm glass core fiber in place. The fiber output facet to the detector is tipped with a focusing lens for optimal coupling onto detector, and the far end of the fiber has an FC connector. This approach offers a “plug and play” solution for attaching a variety of fibers from third party sources via an appropriate FC adapter. Contact your sales representative for recommendations.

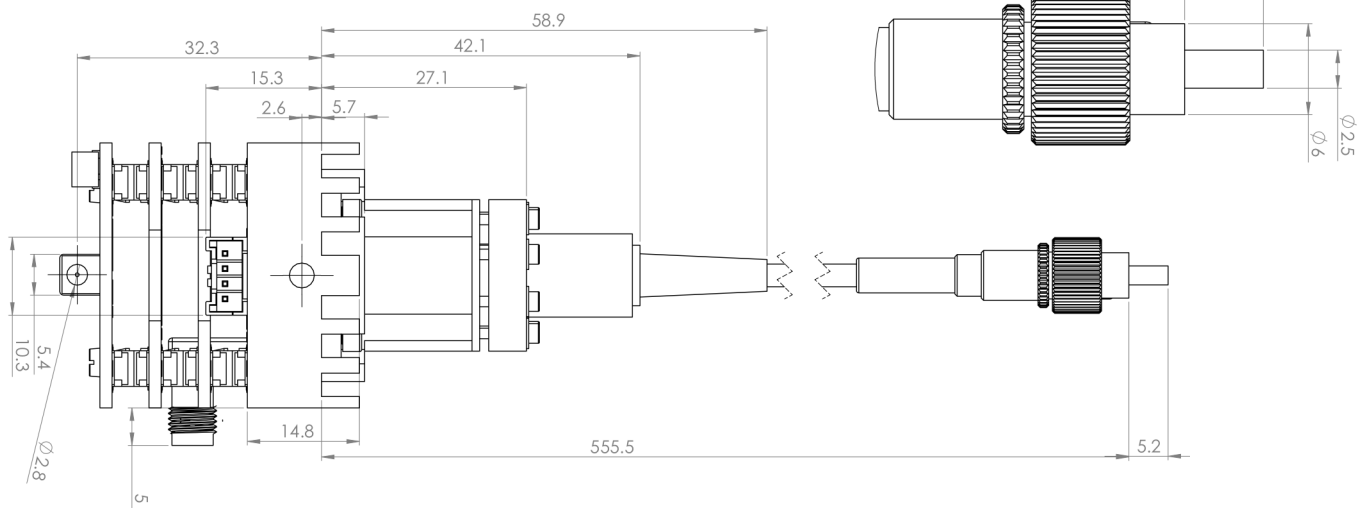
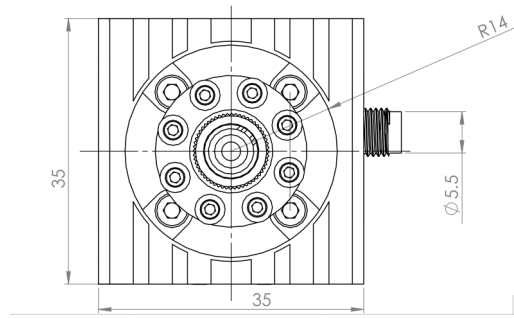

**SCHEMATICS (All Dimensions in mm)**

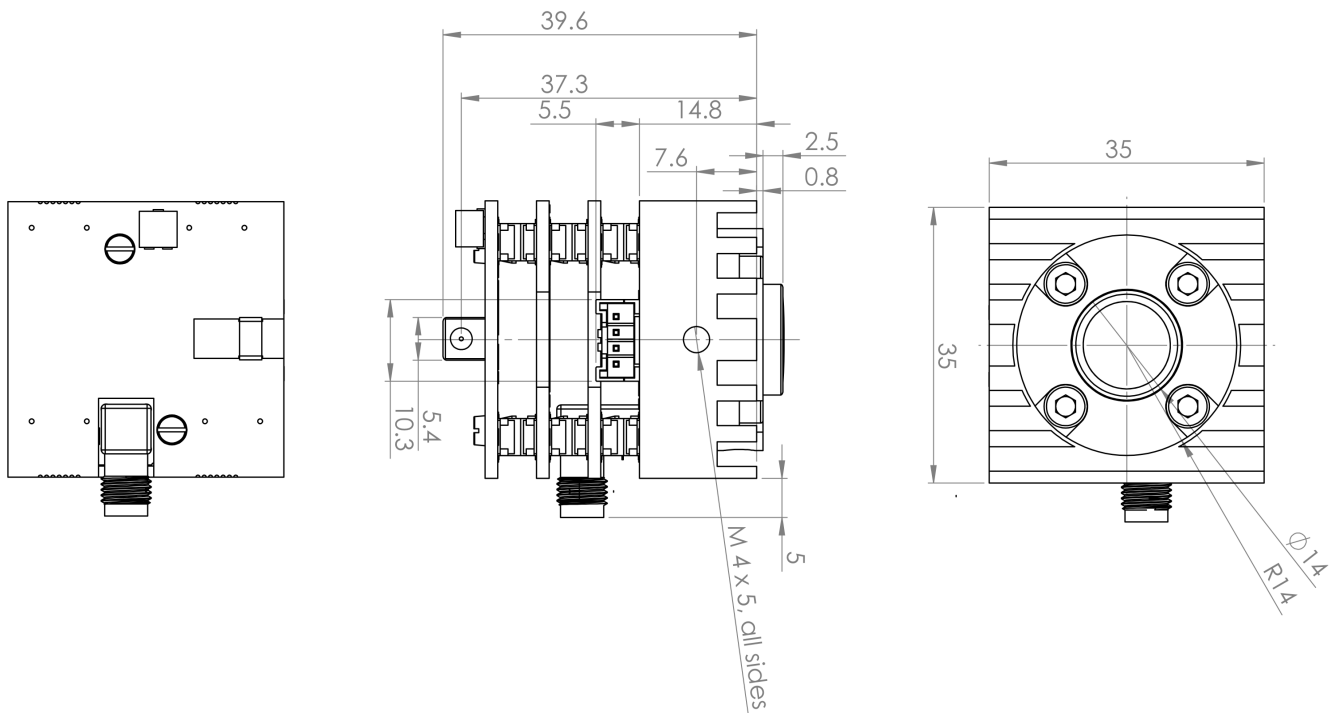

**ORDERING INFORMATION**

Product Code	Microcell size (Total number)	Sensor active area	Description
10000 Series			
MiniSL-10035-X08	35µm (576 microcells)	1mm x 1mm	TO8 package, Peltier TEC with cooling board, heat sink, transimpedance preamplifier, power supply board and mains adapter
30000 Series			
MiniSL-30035-X08	35µm (4774 microcells)	3.05mm x 3.05mm	TO8 package, Peltier TEC with cooling board, heat sink, transimpedance preamplifier, power supply board and mains adapter
Options			
Product Code	Description		
Mini-Opt-CMountM	MiniSL C-mount adapter (male) option		
Mini-Opt-F1	MiniSL fiber coupler (FC, 400µm core) option		

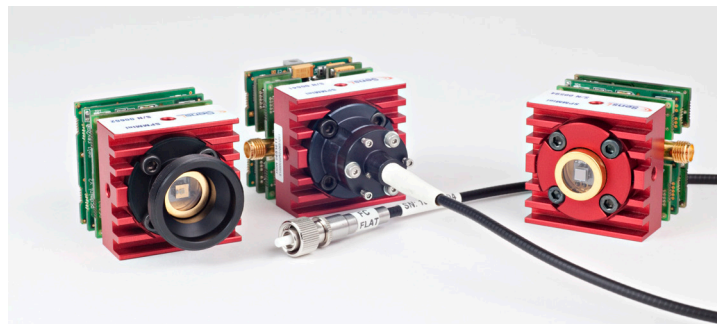

*From left to right, MiniSL with C-mount, MiniSL with Fiber Coupler, MiniSL*